







C38R Technical Data Sheet



OEM Key features

-  **Reliable construction**
-  **Robust and compact design**
-  **No turbo-lag (Instant boost)**
-  **Installation flexibility**
-  **Reduced emission**
-  **Cost efficient solution**
-  **Power range: 340-720kW (455-965hp)**

GENERAL DESCRIPTION

The C38R is the most powerful centrifugal supercharger of the Rotrex standard product range and is available as a clockwise- or counterclockwise-rotating version. Countless number of large-scale applications can be boosted by this very efficient and silent unit which supplies air flow up to 0.84 kg/s. Additionally the C38R shares identical packaging and bracketry dimensioning with the C38 range, thereby allowing direct retro-fit for power upgrades of existing kits and installations.

Impeller speeds of up to 90,000 rpm are achieved through the patented hi-speed planetary traction drive which combines small size with exceptional performance and durability.

The very low noise and vibration characteristic as well as the high efficiency of these superchargers set the industry standard for what is achievable.

The C38R range is designed for high performance four stroke gasoline engines with a supercharged output 720kW. For extreme applications where one supercharger is not sufficient, it is possible to use two units to support large amounts of power in a twin-charger configuration. The C38R is also ideal for the supply large amounts of clean pressurized air for other applications such as industrial systems, fuel cell power plants etc.

The C38R further pushes the limits of ground-breaking compactness thus maintaining a very flexible supercharger installation particularly on engine applications with tight space and where weight and size are essential. The C38R is available as a clockwise and a counterclockwise version.

The supercharger features an integrated dual-action oil pump that works as a dry sump scavenging pump in addition to being the oil supply pump. The self-contained oil system allows flexible positioning of the supercharger on the vehicle and has the benefit of fitting the supercharger without worrying about tampering with the oil system of the engine or any other accessory.

C38R range supercharger

Characteristic	Symbol	C38R-112	C38R-112 CCW
Rotational direction ^[1]	R _{in} direction	CW	CCW
Power range ^[2]	P _{range}	340-720kW (455-965hp)	
Max mass flow rate	M _{flow}	0.84 kg/s	
Max pressure ratio (P _{out} /P _{in})	PR _{max}	3.38	
Mass moment of inertia	I _{Supercharger}	12.165·10 ⁻³ kg·m ²	
Drive ratio	N	1:6.0	
Max drive efficiency	η _{max}	97%	
Unit weight	M	6.4 Kg (14.1 lbs)	
Pulley type	-	Fitted with pulley adapter	
Steel Pulley ring diameters available	Ø _{pulley}	75, 80, 85, 90, 95, 100, 105, 110 mm 8 rib steel - PK profile	
Peak input shaft speed	R _{in} max	15,000 rpm	
Peak impeller speed	R _{out} max	90,000 rpm	
Min inlet oil temperature	Toil,in _{min}	-40°C (-40°F)	
Max inlet oil temperature	Toil,in _{max}	80°C (176°F)	
Mounting torque Pulley ring bolts	M6x10	10Nm (7.4 ft-lb)	
Mounting torque Bracket bolts	M8x85	15Nm (11 ft-lb)	
Mounting torque Oil banjo bolts	M10x1	21Nm (15.5 ft-lb)	

[1] Rotational direction as seen from pulley side, CW: Clockwise, CCW: Counterclockwise.

[2] Power output is dependent on engine type, cooling, cam-timing etc.

Conversion Toolbox

Temperature conversion	$^{\circ}\text{C} = \frac{5}{9} \times (^{\circ}\text{F} - 32)$ OR $^{\circ}\text{F} = \frac{9}{5} \times ^{\circ}\text{C} + 32$		
Kg/s to lb/min conversion	$\frac{\text{kg}}{\text{s}} = 0.0075 \frac{\text{lb}}{\text{min}}$	$\frac{\text{lb}}{\text{min}} = \frac{\frac{\text{kg}}{\text{s}}}{0.0075}$	
Kg/s to CFM conversion	$\text{CFM} = \frac{\text{kg}}{\text{s}} \times 1731.8$	$\frac{\text{kg}}{\text{s}} = \frac{\text{CFM}}{1731.8}$	@15°C and 0.1013 MPa

C38R-112 CW and CCW compressor map

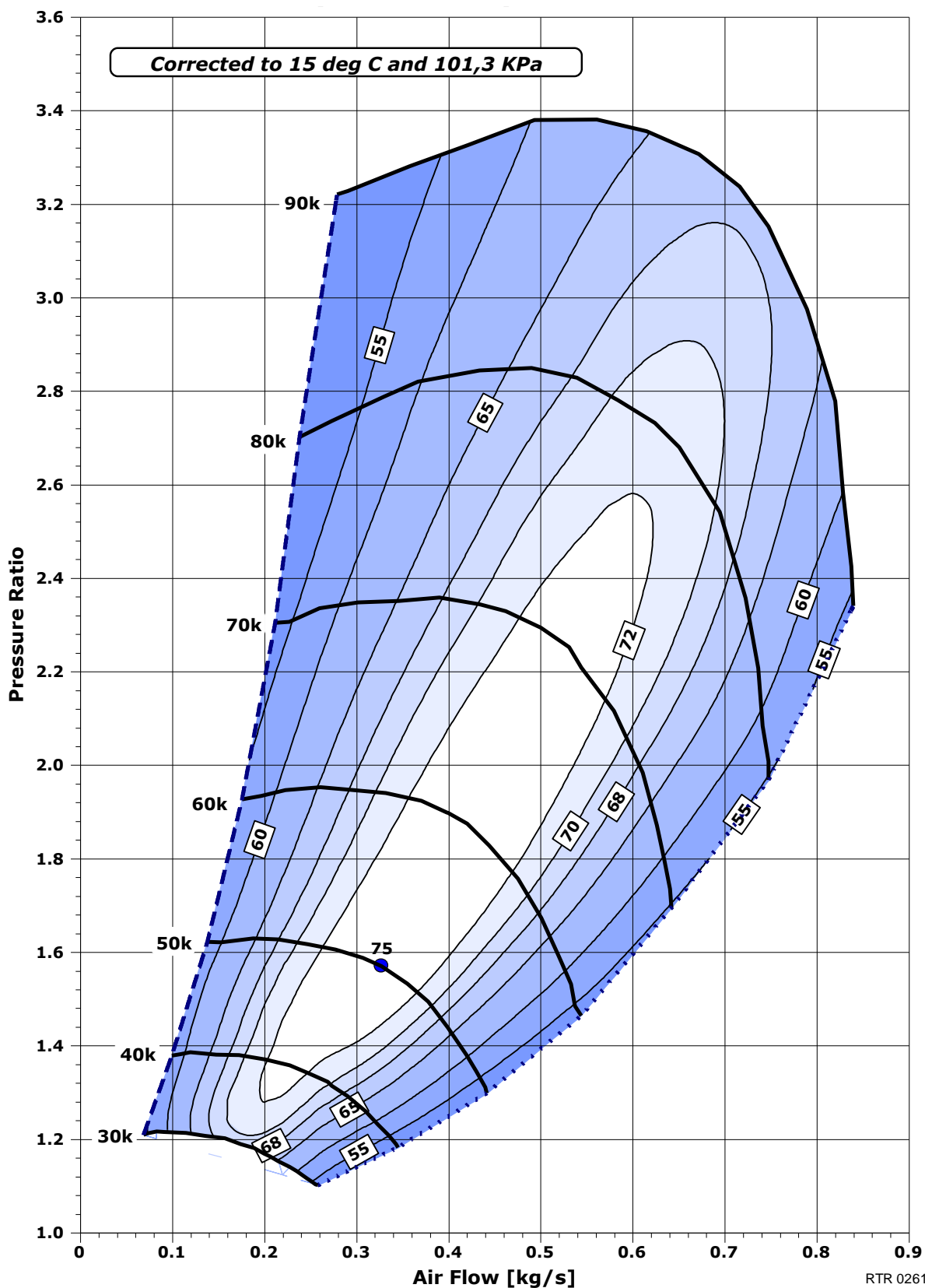

C38R CW Dimensions

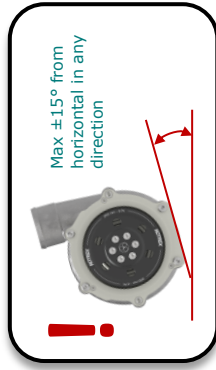

The supercharger can be ordered with the compressor housing mounted in one of six different outlet positions with 60° intervals to allow easy adoption to any application. 0° outlet direction being the Rotrex default

Possible outlet directions

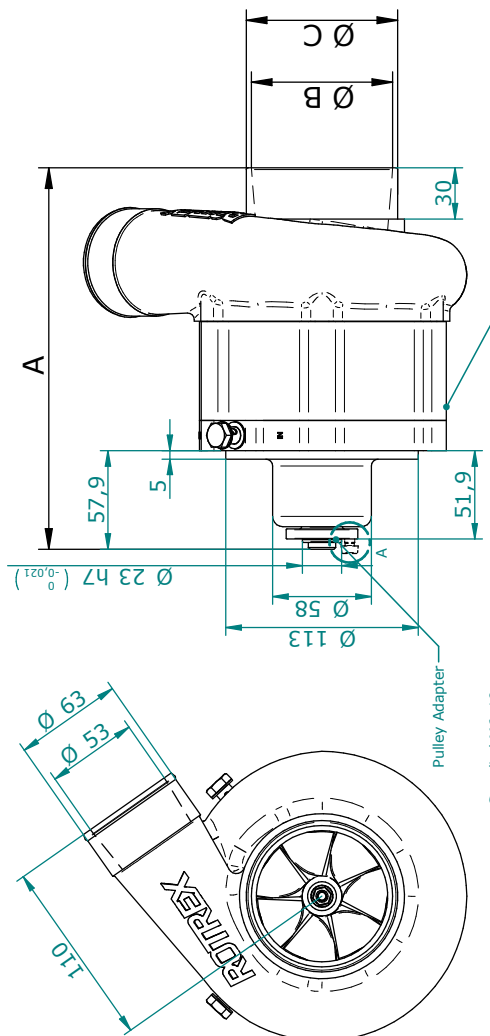
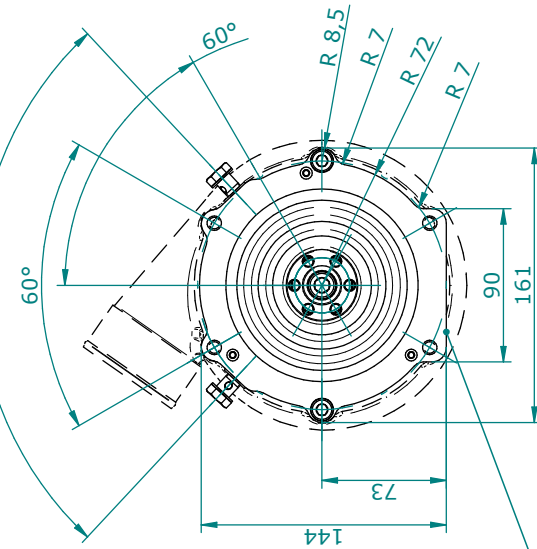
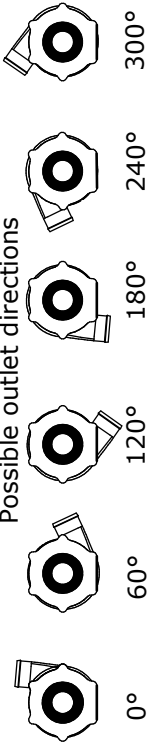

The supercharger must be positioned with the flat part facing down and within 15° from horizontal in any direction

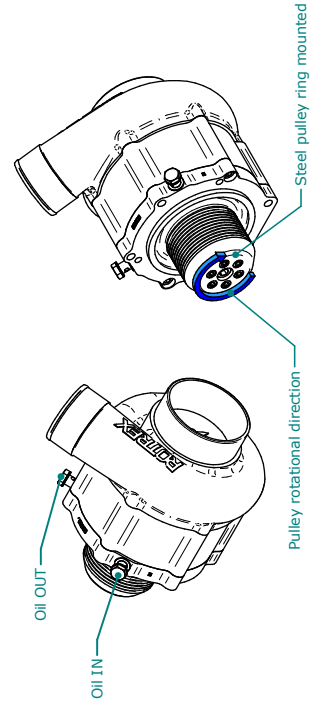

All dimensions in mm unless otherwise specified

	A	B	C
C38R-112	224	83	89

Rotrex steel pulley ring Ø	75	80	85	90	95	100	105	110
----------------------------	----	----	----	----	----	-----	-----	-----

C38R CCW Dimensions

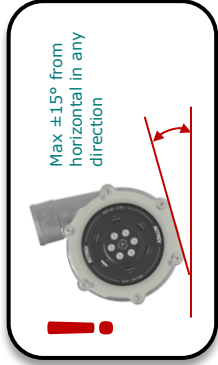

The supercharger can be ordered with the compressor housing mounted in one of six different outlet positions with 60° intervals to allow easy adoption to any application. 0° outlet direction being the Rotrex default

Possible outlet directions

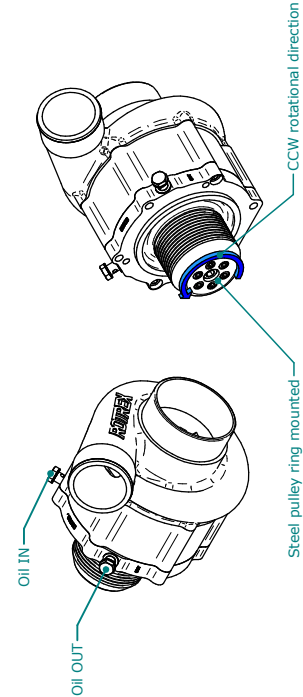
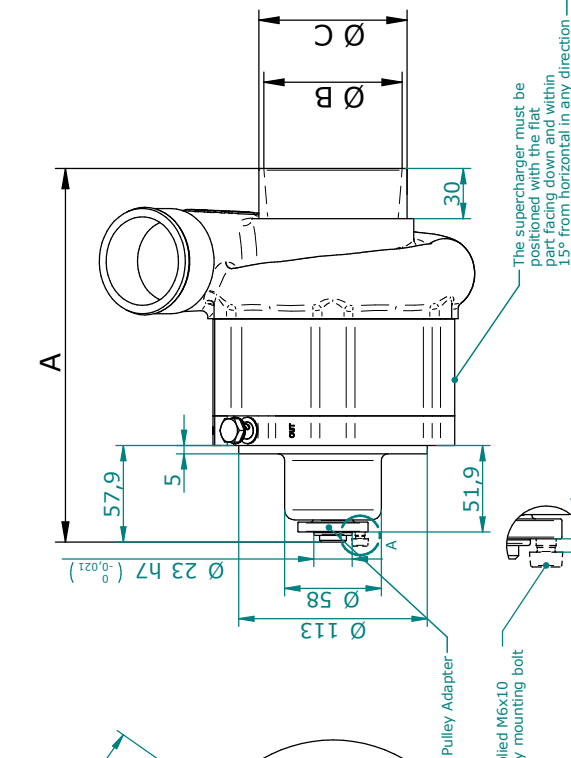
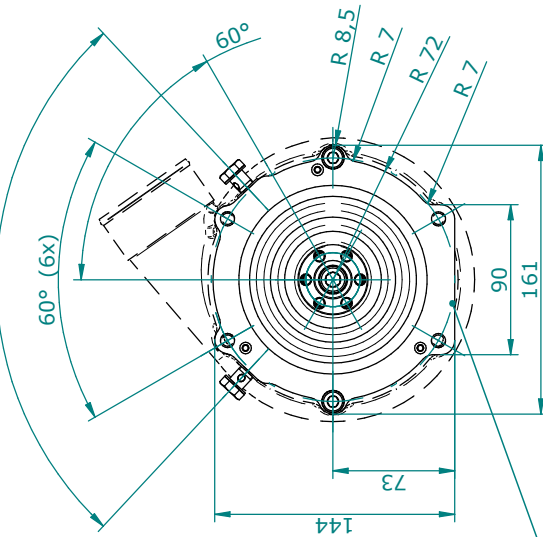
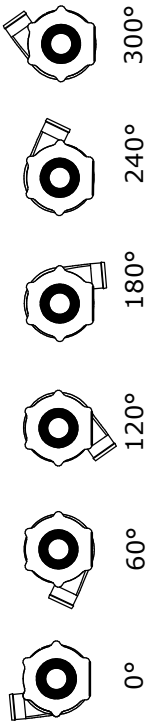

All dimensions in mm unless otherwise specified

	A	B	C
C38R-112 CCW	224	83	89

Rotrex steel pulley ring Ø	75	80	85	90	95	100	105	110
----------------------------	----	----	----	----	----	-----	-----	-----